

Technical Data Sheet

Product Name	
Full Product Name	Unicote 315 HS 2K PU
Type of Product	2K acrylic urethane topcoat
Description	Concept Unicote 315 HS 2K PU is a 2K acrylic urethane topcoat, characterised by its high-volume solids , high build durability, excellent flow and gloss. It is suitable for large industrial and commercial applications where a high solids system is required.

Tinters						
Product Name	Volume Solids %	Weight Solids %	Density		VOC	
			g/mL	lbs/US gal	g/L	lbs/US gal
341 White	70.0	84.7	1.909	15.93	291.2	2.43
342 Yellow Ochre	63.5	79.0	1.689	14.10	354.6	2.96
343 Black	60.2	64.5	1.083	9.04	384.1	3.21
344 Bright Blue	52.6	53.8	1.163	9.71	537.5	4.49
345 Green Blue	56.7	61.4	1.088	9.08	419.8	3.50
346 Violet	53.9	54.4	1.122	9.36	512.0	4.27
347 Bright Red	58.1	64.4	1.141	9.52	406.8	3.40
348 Magenta	58.6	62.6	1.072	8.94	401.4	3.35
349 Bright Yellow	56.2	62.2	1.125	9.39	425.4	3.55
350 Mid Yellow	44.2	50.1	1.085	9.06	541.8	4.52
351 Scarlet	59.8	68.5	1.240	10.35	390.3	3.26
352 Green	55.6	59.5	1.234	10.30	500.3	4.18
353 Dark Red Oxide	61.6	76.9	1.612	13.46	372.6	3.11
354 Jet Black	53.1	56.7	1.053	8.78	455.5	3.80
355 Red	63.1	66.1	1.187	9.91	402.4	3.36
371 Reduced Yellow Ochre	62.5	68.7	1.161	9.69	363.9	3.04
372 Reduced Black	61.8	65.0	1.059	8.84	370.3	3.09
373 Reduced Green Blue	60.6	64.3	1.060	8.85	378.9	3.16
374 Reduced Scarlet	61.8	66.0	1.093	9.12	371.2	3.10
375 Reduced Green	60.8	63.8	1.092	9.11	395.5	3.30
381 Silver	41.4	54.4	1.171	9.78	533.7	4.45
382 Coarse Silver	42.5	51.4	1.116	9.31	541.4	4.52
399 Flattening Base	35.9	43.2	1.094	9.13	621.5	5.19

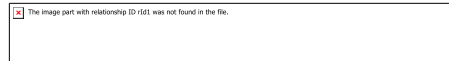

Technical Data Sheet

Products

Product Name	Volume Solids %	Weight Solids %	Density		VOC	
			g/mL	lbs/US gal	g/L	lbs/US gal
315 HS 2K PU mixed colour -	70%	58.8%	1.15	8.92	478.7	3.86
241 PU Hardener (4:1) Normal	33.9	39.9	0.986	8.23	593.1	4.95
241 PU Hardener (4:1) Fast	33.6	40.2	0.968	8.08	578.3	4.83
241 PU Hardener (4:1) Slow	35.4	40.9	1.004	8.38	593.8	4.96
831 2K Thinner Slow	0.0	0.0	0.893	7.45	892.7	7.45
831 2K Thinner Normal	0.0	0.0	0.882	7.36	881.9	7.36
831 2K Thinner Fast	0.0	0.0	0.872	7.27	871.5	7.27

Properties

- Superior performance
- High gloss
- Quick and easy application



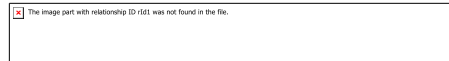

Substrates

- Mild Steel
- Aluminium
- Galvanised Iron
- Glass Reinforced Plastics (GRP)
- Previously painted substrates in sound condition



Technical Data Sheet

Substrate Preparation	
 Mild Steel	DTM: Sand with 240 Frecut Primer: <u>Optimal:</u> Concept 2K HS Primer or Concept 136 Epoxy Primer(Urethane), or Concept 141 Epoxy Primer Standard: Apply Concept 103 Etch Primer or Concept 111 Universal Primer(HB) Sand with P600 wet or dry
Aluminium	<u>Optimal:</u> Apply Concept 2K 141 Epoxy Primer or Concept 132 2K Etch Primer with Concept 2K HS Primer <u>Standard:</u> Apply Concept 103 Etch Primer or Concept 110 Metal Etch or Concept 111 Universal Primer(HB) Sand with P600 wet or dry
Galvanised Iron	<u>Optimal:</u> Apply Concept 2K 141 Epoxy Primer, or Concept 132 2K Etch Primer with Concept 2K HS Primer <u>Standard:</u> Apply Concept 103 Etch Primer or Concept 110 Metal Etch or Concept 111 Universal Primer(HB) Sand with P600 wet or dry
Glass Reinforced Plastics (GRP)	<u>Optimal:</u> Apply Concept 2K 141 Epoxy Primer or Concept 2K HS Primer <u>Standard:</u> Apply Concept 103 Etch Primer or Concept 111 Universal Primer(HB) Sand with P600 wet or dry
Previously painted Surfaces (in soundcondition)	Sand with P600 wet or dry
Special Notes: <ul style="list-style-type: none"> All surfaces must be thoroughly sanded and cleaned with Concept Wax & Grease Remover prior to application. Use white or light coloured primers under bright yellows, oranges and reds, if required. The above systems are examples only. For further information, please contact Concept Paints Technical Representative. 	

Product Preparation			
 	<ul style="list-style-type: none"> Weigh the concentrates into the required base in accordance with the relevant colour formula. A maximum of only 10% reduced concentrates is allowed and a maximum of 35% for all concentrates, in total. Stir or shake for a minimum of 10 minutes Never leave the mixture stand for more than 30 minutes before mixing. 		
 Mixing Ratio 4:1 (by volume)		Concept 315 HS 2K PU	Concept 241 PU Hardener (4:1)
		4 parts	1 part
 Reducer	Up to 10% (v/v) Concept 2K Thinner, if required		

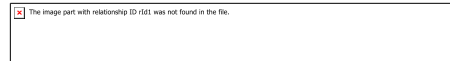

Product Preparation cont

	Matting (if required)	Satin Finish: Add 30% of 399 Flattening Base. Matt Finish: Add 45% of 399 Flattening Base. Notes: <ul style="list-style-type: none"> • Never add more than 50% of 399 Flattening Base. • 399 Flattening Base must be added before adding a hardener or thinner. • The addition of 399 Flattening Base will reduce coverage. 			
	Pot life @ 25°C (77°F)	2-3 hours			
	Spray viscosity @ 25°C (77°F)	BSB 4 Cup Ford 4 Cup	18-20 s 16-17 s		
	Spray equipment	Gun type	Fluid tip	Spray pressure	Spray Distance
		Gravity Feed	1.2-1.4 mm 0.047-0.055"	200-240 kPa 2.0-2.4 bar 30-35 psi	15-20 cm 6-8 inch
		Suction feed	1.5-2.0 mm 0.059-0.079"	200-240 kPa 2.0-2.4 bar 30-35 psi	15-20 cm 6-8 inch
		HVLP	1.2-1.3 mm 0.047-0.051"	40-70 kPa 0.4-0.7 bar 6-10 psi	15-20 cm 6-8 inch
		Airless, Air Assisted, Electrostatic	Consult the manufacturer's instructions.		
	Number of coats	2-3	Apply one light coat followed by one or two even full coats. Avoid heavy wet coats.		
	DFT Recommended	50 µm 2.0 mils			
	Flash off time @ 25°C (77°F)	15 - 20 min between coats			
	Drying	Air Dry @ 25°C (77°F)	Tack Free: 4 hours Recoatable with itself after any time.		

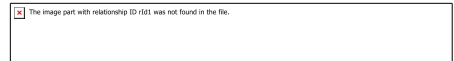

This data relates only to the material designated herein and does not apply to use in combination with any other material or any process. The data is not to be considered as a warranty or quality specification and we assume no liability in connection with its use.



Date: 20th July, 2018

Technical Data Sheet

Version: 01

Remarks	
	Stir all products thoroughly each time before use. Stir the mixture well after the weigh-out of the components.
	Before application a colour comparison is recommended
	Surface temperature must always be a minimum of 3°C (5°F) above dew point.

Equipment Cleaning	
Use recommended Concept Paints cleaner such as Concept Gunwash or Multi-Thinner	

Dry Film Properties	
	After 7 days drying, when compared to similar technology products.
Gloss 60/20°	94/87
Water resistance	Excellent
Petrol resistance	Excellent
Durability	Excellent

Product Data	
Theoretical Coverage	Approx. 8.0 m ² /L (325 ft ² /US gal) @ recommended DFT
Shelf Life	36 months in an unopened container at room temperature, away from sunlight.

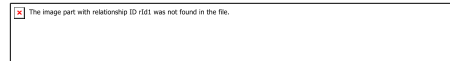

Product Packaging

Product Code 1	Product Code 2	Product Name	Package Size
G/341-G/355	3410341-3410355	Tinters	1L, 4L
G/381-G/382	3410381-3410382	Metallic Tinters	1L, 4L
G/371-G/375	3410371-3410375	Reduced Tinters	1L
G/399	3410399	399 Flattening Base	1L, 4L
IN31590000020	3159000	315 HS 2K PU	20L
IN24192000.25	2419200	241 PU Hardener (4:1) Normal	250mL
IN24192000001	2419200	241 PU Hardener (4:1) Normal	1L
IN24193000.25	2419300	241 PU Hardener (4:1) Fast	250mL
IN24193000001	2419300	241 PU Hardener (4:1) Fast	1L
IN24191000.25	2419100	241 PU Hardener (4:1) Slow	250mL
IN24191000001	2419100	241 PU Hardener (4:1) Slow	1L
IN83191000020	8319100	831 2K Thinner Slow	20L
IN83192000020	8319200	831 2K Thinner	20L
IN83193000020	8319300	831 2K Thinner Fast	20L

Safety

For automotive and industrial use only by professional painters. Not recommended for sale to, or use by the general public. Before using, read and follow all label and Safety Data Sheet (SDS) precautions. If mixed with other components, the mixture will have hazards of all individual components.

Read and understand the Guidelines for the Safe Handling and Use of Isocyanate Containing Paints, including the use of approved respiratory protection and Personal Protective Equipment. Use only in a well-ventilated approved spray booth, according to local regulations.

The information provided in this documentation has been carefully selected and arranged by us. It is based upon our best knowledge on the subject at the date of issuance. The Information is given for information purposes only. We are not liable for its correctness, accuracy and completeness. It is up to the user to check if the information is current and the product is suitable for its intended purpose. The intellectual property in this Information, including patents, trademarks and copyrights, is protected. All rights reserved.

We may modify and/ or discontinue operation of all or portions of this Information at any time in our sole discretion, without notice and assume no responsibility to update the Information. All rules set forth in this clause shall apply accordingly for any future changes and amendments.

This Technical Data Sheet supersedes all previous issues.

Concept Paints
 26-30 Charles Street
 St Marys NSW 2760
 Sydney, Australia

ph. +61 (2) 9673 2555
 fax. +61 (2) 9623 1918
 info@conceptpaints.com.au
 www.conceptpaints.com.au